

# APPLYING RANK POSITIONAL WEIGHT METHOD TO INCREASE THE EFFICIENCY OF LINE BALANCING IN A HOME THEATRE INDUSTRY

Anastasia Lidya Maukar  
Faculty of Technology, Industrial Engineering Department, President University  
Jl. Ki Hajar Dewantara  
Kota Jababeka, Cikarang, Bekasi - Indonesia 17550  
Email: almaukar@gmail.com

## ABSTRACT

*In order to improve the current situation along the production line of a Home Theatre, a method of line balancing should be implemented. The difference of workload is the cause problem which affects the output produced. This leads to an idle time in the production process resulting in loss of production capacity. This research uses a method of Rank Positional Weight to solve the problem. The aim of this research is to get a proposed line with a higher efficiency than the imbalance workload in the current situation. This research is started with collecting the time study and calculate the standard time. Followed by calculation of efficiencies, construction of yamazumi's chart and precedence diagram, application of Rank Positional Weight Method, and last is calculation of efficiency of the proposed line.*

**Keywords:** assembly line balancing, Rank Positional Weight method, Yamazumi's chart

## I. INTRODUCTION

Line balancing commonly occurred in the assembly process rather than the manufacturing process. An effective line balancing requires assuring that every line segments production quota can be met within the time frame using the production capacity. There are some combinations of jobs assignments that might occur(s) that are in charge of a particular work is the beginning of the line balancing problem as the assignment of different elements of work gives out different unproductive time and variation in the works required to produce the goods as an output.

Nowadays, the competition among companies has been rising. In order to survive in this situation, they have to fight over a large market scale. A good performance in a company could be seen when outputs that they produce have a great degree of flexibility and capability to fulfill customer's satisfaction.

As an electronic industry who produces electronic appliances, such as television, set up box as well as home theatre studio, they have to fulfill the local market as well as export purposes to fulfill the global market. In the home theatre studio production, there are two lines which are Line AE and Line AP. This research was focused on Line AP as it has many operations and more output per day.

The workstation in Line AP includes input process, assembly process, screwing process, inspection process, scan our process, assembly cushion, input kitting speaker, remove dummy, insert set, attach label on packing case, tapping and arrange to pallet. With a total of 12 workstation, it consists 78 operations and 36 operators working for the line.

## II. ASSEMBLY LINE BALANCING

### A. Rank Positional Weight Method

Positional Weight Method is also known as Helgeson-Birnie Method. The steps involved in these techniques are (Elsayed, 1994):

1. By first develop a precedence diagram, which shows the relationship between operations towards another operation.
2. Determines the positional weight of the operation that correspondence at the precedence diagram with the longest path taken from the beginning until the end of the process.

3. After getting the positional weight of the operations, we can then rank them from the highest to the lowest.
4. Re-assign the elements of the operations into the workstation without violating the relationship of the precedence diagram and without exceeding the takt time.
5. Repeat step 3 and 4 until all operations are assigned.

**B. Line Balancing Performance**

1. Line Efficiency

The line efficiency is the ratio of a total working time divided by the station cycle times and the number of workstations (Elsayed, 1994). The highest optimization can be calculated by 100% line balancing efficiency which means that all processes in the production line have the same cycle time. It is calculated as:

$$LE = \frac{\sum_{i=1}^k T_i}{(K) \cdot (CT)} \times 100\% \tag{1}$$

Where:

T<sub>i</sub> = time from workstation 1 to -i

K = Number of workstations

CT = Cycle time

2. Balance Delay

Balance delay is a measure of the line efficiency which results from idle time due to imperfect allocation of work among the stations (Elsayed, 1994). The ideal number of balance delay is 0%. It is calculated as:

$$BD = 100\% - LE \tag{2}$$

**III. Research Methodology**

The steps of conducting this research are described as follows:

1. First, direct observation in the company was conducted to gather all the data and determine the area of the company that is going to be focused. Second step was collecting information and have some discussion with the staff and employee about the problem in the area.
2. Determining the problem statement. The problem is the low line efficiency in the Home Theatre production finishing process due to an unbalance workload among each operator.
3. The next step is data collection. The data that have been collected are: Production targets for Home Theatre product per shift, cycle time of each processing during the assembling production line, and standard time for each operation using time motion study.
4. Data calculation and analysis. There are several steps that are used in data calculation and analysis:
  - From the time motion study, the normality test, uniformity test and sufficiency test was conducted. Those test are to check whether the data gathered for the observation are normal, within the range limit, as well as sufficient.
  - Calculating the normal time by getting the average observe time first then multiply it by the performance rating.
  - Calculating the standard time of each operation in the production line. To calculate the standard time, the normal time calculation as well as the allowance calculation is needed.

- After getting the standard time of each operation, the precedence diagram can be constructed. This is to see the relationship between operations towards another.
- Calculating the line efficiency, balance loss, number of operators as well as the outputs produced in one shift in the current situation.
- Applying the Rank Positional Weight Method to get the new arrangement of operations without violating the precedence diagram and to get the proposed line and calculate its line efficiency, balance loss, number of operator, and the output produced in one shift.
- Comparing the result between the current situation and the proposed line.

**IV. Result and Discussion**

**A. Current Situation**

Table 1 shows yamazumi’s chart for each workstation in the Home Theatre production. Yamazumi chart is a bar graph typically showing the balance of workloads as operator cycle times that can be used for load planning and scheduling. This chart is also useful in order to detect whether the cycle time of an operator exceed the takt time and visually present the work content of a sequence of tasks and facilitate work balancing and the isolation and elimination of non-value added work content (F., Talip et al, 2011). It can be seen the workstation which violate the takt time. It leads to a high waiting time when one or more workstations violate the takt time.

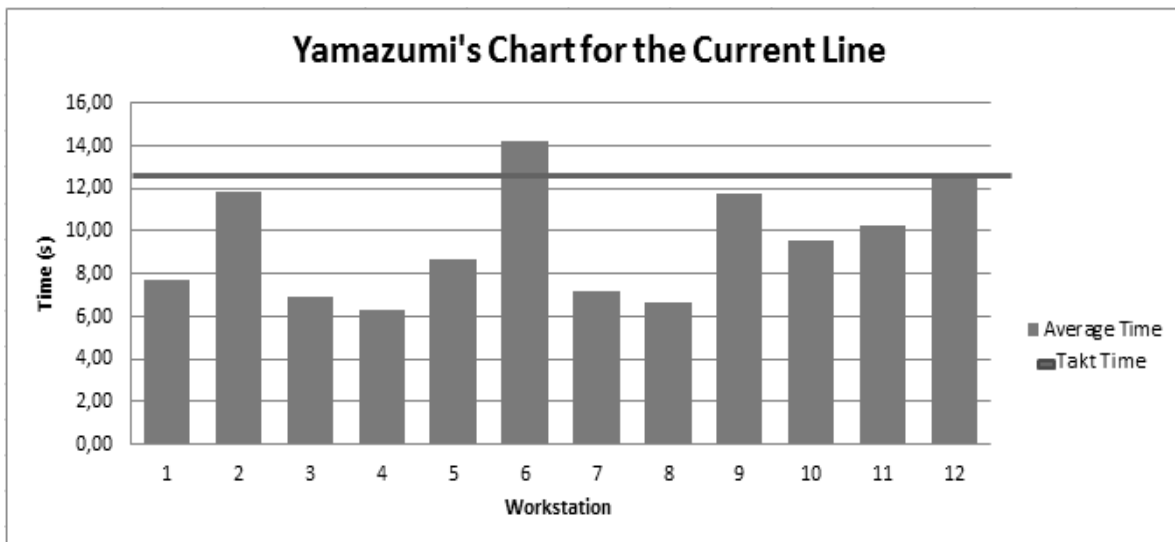

**Figure1.** Yamazumi’s Chart for the current line

The line efficiency of the current situation is:

$$LE = \frac{113.33}{14.18 \times 12} \times 100\% = 66.60 \%$$

The balance delay of the current line is calculated as:

$$BD = 100\% - 66.60\% = 33.40 \%$$

In addition, the smoothness index in the current situation should be calculated to support the comparison of the current situation and the proposed one. Smoothness index can be calculated as:

$$\begin{aligned}
 SI &= \sqrt{(14.18 - 7.70)^2 + (14.18 - 11.87)^2 + (14.18 - 6.89)^2 +} \\
 &\quad (14.18 - 6.29)^2 + (14.18 - 8.69)^2 + (14.18 - 14.18)^2 +} \\
 &\quad (14.18 - 7.15)^2 + (14.18 - 6.66)^2 + (14.18 - 11.72)^2 +} \\
 &\quad (14.18 - 9.50)^2 + (14.18 - 10.27)^2 + (12.66)^2} \\
 &= \sqrt{344.3866} \\
 &= 18.56
 \end{aligned}$$

The output produced per shift is calculated as:

$$\frac{28800 \text{ sec}}{14.18 \text{ sec}} = 2032 \text{ set/day}$$

**B. Proposed Line**

By using the Ranked Positional Weight Method (RPW Method) and checking the precedence diagram, the first step was determining the position weight of each operation from the beginning of the process to the end of the process in line AP (the longest time it takes). The calculation of Positional Weight for operation O-1 is:

$$\begin{aligned}
 &O-1+O-3+O-4+O-5+O-6+O-7+O-9+O-11+O-12+O-13+O-14+O-15+O-19+O-20+O- \\
 &21+O-22+O-23+O-24+O-25+O-26+O-27+O-28+O-29+O-30+O-31+O-32+O-33+O- \\
 &34+O-35+O-36+O-37+O-38+O-39+O-40+O-41+O-42+O-43+O-44+O-45+O-46+O- \\
 &47+O-48+O-49+O-50+O-51+O-52+O-53+O-54+O-55+O-56+O-57+O-60+O-61+O- \\
 &64+O-65+O-71+O-74+O-73+O-75+O-76+O-77+O-78 = 72,33
 \end{aligned}$$

Calculation of positional weight for each operation is presented as Appendix 3.

After calculating the entire positional weight of the operations, the PW is then being ranked starting from the highest value to the lowest value. The ranking result is shown as Appendix 4.

The next step of constructing an improved line is by re-assigning the operations into the right workstations. This is based on the Rank Positional Weight which also depends on the precedence diagram, with some rules that are considered.

Table 2 shows the average time in a form of yamazumi’s chart for the workstation with new arrangements of operations.

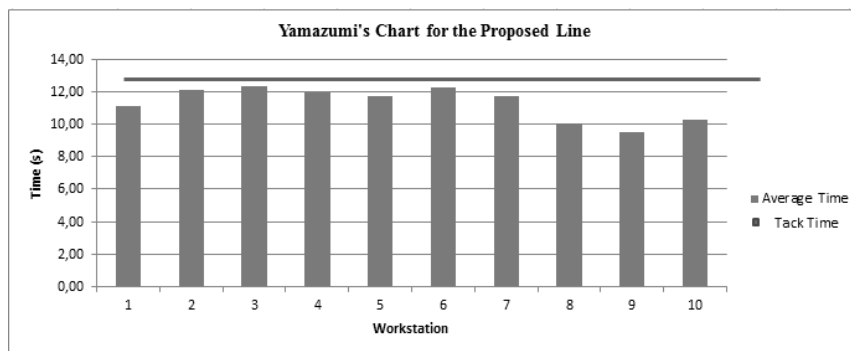

**Figure2.** Yamazumi’s Chart for the proposed line

The line efficiency of the proposed line is 91.84% and the balance delay of the proposed is 8.16%. Smoothness Index in the proposed line is 7.17.

In addition, the output produced per shift is calculated as:

$$\frac{28800 \text{ sec}}{12.34 \text{ sec}} = 2333 \text{ sets/day}$$

**C. Comparison between Current Situation and Proposed Line**

Table 1 shows the summary of the comparison between the current situation with the proposed line.

**Table 1.** comparison between current situation with the proposed line

Description	Current Line	Proposed Line
Line Efficiency	66.60%	91.84%
Balance Delay	33.40%	8.16%
Smoothness Index	18.56	7.17
Number of Operator	36	30
Output/day	2320 sets	2333 sets

Table 1 explains that the line efficiency increases by 38% from the value of 66.60% to 91.84%. When the line efficiency increases, the balance delay and smoothness index decreases. The balance delays decreases by 25.24% while the smoothness index decreases by 11.39%. The number of operators also decreases to 30 workers as the number of workstation was decreased. The output per day also increases to 2333 sets.

The total cost is calculated based on the payment for the operators. The minimum regional wage is Rp.2,400,000/month/operator and the calculation is shown as table 2 below. The result is the total cost per month decreasing by 16.67%.

**Table 2.** Comparison between current situation with the proposed line in terms of cost

	Current Situation (36 operators)	Proposed Line (30 operators)
The total cost for operators / month	Rp. 86,400,000	Rp. 72,000,000

**V. CONCLUSION**

In this research, there are some improvements to increase the line of balancing efficiency. It is proved that in the proposed line, the line efficiency increased from the value of 66,60% to 98,84%. The decrease of the balance delay by 76%, smoothness index by 61% and for the number of operators are also decreased from 36 worker to 30 worker. The reason is because of the decreasing of the number of workstation to 10.

**VI. REFERENCES**

[1] Becker, C., and Scholl, A., 21/2003, "A survey on problems and methods in generalized assembly line balancing", accessed on September 2012

[2] Boysen, N., Fliedner, M., and Scholl, A., 23/2006, "Assembly line balancing: Which model to use when?" , Friedrich-Schiller-Universitat Jena, accessed on September 2012

[3] Buchkin, J., Dar-El, E., Rubinovitz, J., 2002, "Mixed-model assembly line design in a make-to-order environment, computers & Industrial Engineering", accessed on December 2012

[4] Elsayed, E., and Boucher, T., 1994, "Analysis and Control of Production Systems", Prentice-Hall, New York.

[5] F. Talip, Hussin, M., and Zailani, Z., vol. 3 no. 5, May 2012. "The Study of Manufacturing Considerations of Fishery Product", School of Manufacturing Engineering, Universiti Malaysia Perlis, accessed on January 2013.

- [6] Niebel, W., and Freivalds, A., 2009, "*Niebel's Methods, Standards, and Work Design*", McGraw-Hill, New York.
- [7] Sitalaksana, I., Anggawisastra, R., and Tjakraatmadja, J., 2006, "*Teknik Perancangan Sistem Kerja*", ITB, Bandung.
- [8] Wignjosoebroto, S., 2006, "*Ergonomi Studi Gerak dan Waktu*", Guna Widya, Surabaya.

### Appendices

#### Appendix 1 : Standard Time of each operations

work Element	Standard Time (second)	work Element	Standard Time (second)	work Element	Standard Time (second)
O-1	1.46	O-28	0.13	O-55	0.17
O-2	0.98	O-29	0.21	O-56	0.16
O-3	1.12	O-30	0.10	O-57	0.12
O-4	2.26	O-31	0.09	O-58	2.72
O-5	1.18	O-32	0.16	O-59	2.74
O-6	0.70	O-33	0.15	O-60	3.23
O-7	1.60	O-34	0.31	O-61	3.77
O-8	1.87	O-35	0.14	O-62	2.46
O-9	3.23	O-36	0.14	O-63	2.78
O-10	2.80	O-37	0.22	O-64	3.46
O-11	1.09	O-38	0.10	O-65	1.71
O-12	1.30	O-39	0.20	O-66	7.15
O-13	0.33	O-40	0.09	O-67	6.66
O-14	0.33	O-41	0.19	O-68	2.31
O-15	0.65	O-42	0.18	O-69	2.90
O-16	1.27	O-43	0.12	O-70	2.47
O-17	0.68	O-44	0.22	O-71	4.04
O-18	0.49	O-45	0.39	O-72	1.86
O-19	0.78	O-46	0.24	O-73	3.38
O-20	0.64	O-47	0.27	O-74	2.35
O-21	0.69	O-48	0.14	O-75	1.91
O-22	0.55	O-49	0.10	O-76	10.27
O-23	0.48	O-50	0.10	O-77	2.91
O-24	0.15	O-51	0.45	O-78	9.50
O-25	0.18	O-52	0.11		
O-26	0.35	O-53	0.33		
O-27	0.15	O-54	0.10		

**Appendix 2 : Precedence Diagram of Line AP**

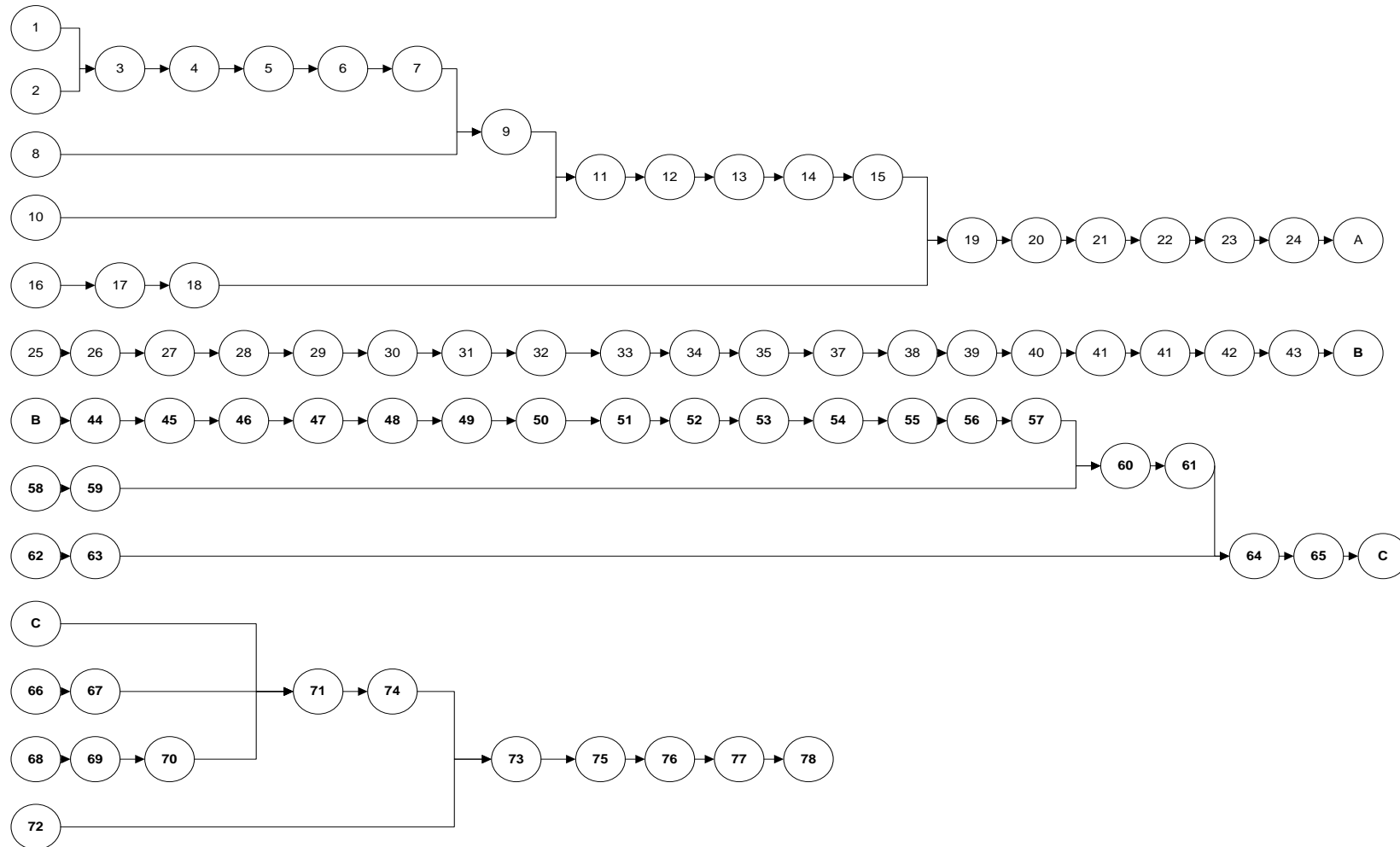



**Appendix 3 : Positional Weight of the operations**

Operation	Positional Weight	Operation	Positional Weight	Operation	Positional Weight	Operation	Positional Weight
O-1	72,33	O-21	55,66	O-43	50,7	O-65	36,07
O-2	71,85	O-22	54,97	O-44	50,58	O-66	48,17
O-3	70,95	O-23	54,42	O-45	50,36	O-67	41,02
O-4	69,75	O-24	53,94	O-46	49,97	O-68	42,04
O-5	67,49	O-25	53,79	O-47	49,73	O-69	39,73
O-6	66,31	O-28	53,11	O-48	49,46	O-70	36,83
O-7	63,31	O-29	52,98	O-49	49,32	O-71	34,36
O-8	65,88	O-30	52,77	O-50	49,22	O-72	29,83
O-9	64,01	O-31	52,67	O-51	49,12	O-73	27,97
O-10	63,58	O-32	52,58	O-52	48,67	O-74	30,32
O-11	60,78	O-33	52,42	O-55	48,13	O-75	24,59
O-12	59,69	O-34	52,27	O-56	47,96	O-76	22,68
O-13	58,39	O-35	51,96	O-57	47,8	O-77	12,41
O-14	58,39	O-36	51,82	O-58	53,14	O-78	9,5
O-15	57,73	O-37	51,68	O-59	50,42		
O-16	59,52	O-38	51,46	O-60	47,68		
O-17	58,25	O-39	51,36	O-61	44,45		
O-18	57,57	O-40	51,16	O-62	45,92		
O-19	57,08	O-41	51,07	O-63	43,46		
O-20	56,3	O-42	50,88	O-64	40,68		

**Appendix 4 : Rank of the operations after calculating the positional weight**

Rank	Operation	Rank	Operation	Rank	Operation	Rank	Operation
1	O-1	17	O-15	41	O-40	65	O-68
2	O-2	18	O-18	42	O-41	66	O-67
3	O-3	19	O-19	43	O-42	67	O-64
4	O-4	28	O-58	44	O-43	68	O-69
5	O-5	29	O-28	45	O-44	69	O-70
6	O-6	30	O-29	46	O-59	70	O-65
7	O-8	31	O-30	55	O-53	71	O-71
8	O-7	32	O-31	56	O-54	72	O-74
9	O-9	33	O-32	57	O-66	73	O-72
10	O-10	34	O-33	58	O-55		
11	O-11	35	O-34	59	O-56		
12	O-12	36	O-35	60	O-57		
13	O-16	37	O-36	61	O-60		
14	O-13	38	O-37	62	O-62		
15	O-17	39	O-38	63	O-61		
16	O-14	40	O-39	64	O-63		